

EVALUATION OF DRIPPER EFFICIENCY WITH THE USE OF FERTILIZER

SONI WILLIAN HAUPENTHAL¹; MARCIO ANTONIO VILAS BOAS¹; NAILA CRISTINA KEPP¹; JAIR ANTONIO CRUZ SIQUEIRA² E LUCIENE KAZUE TOKURA²

¹*Centro de Ciências Exatas e Tecnológicas, Programa de Pós-Graduação em Engenharia Agrícola (Unioeste), R. Universitária, 2069 - Jardim Universitário CEP 85819-110, Cascavel-PR, Brasil. soniwillian@hotmail.com; marcio.vilasboas@unioeste.br, naila.kepp@unioeste.br*

²*Centro de Ciências Exatas e Tecnológicas, Programa de Pós-Graduação em Engenharia de Energia na Agricultura (Unioeste), R. Universitária, 2069 - Jardim Universitário CEP 85819-110, Cascavel-PR, Brasil. jair.siqueira@unioeste.br; lucienetokura@gmail.com*

1 ABSTRACT

The work aimed to analyze the uniformity of drip fertigation compared to the use of water alone, analyzing by the Tukey test at 5% significance for CUC and DUC, defining the process capability from the process capacity index (Pc). The experiment was carried out on a test bench in the irrigation and fertigation laboratory (LIF) of the University of Western Paraná, where in the first treatment, water was used for the irrigation process and in the second treatment, commercial fertilizer was diluted in the reservoir to perform the fertigation. The experimental statistics are constituted in an analysis of variance with subsequent unfolding of the interaction and Tukey test at 5% probability to compare the averages of uniformity, flow and pressure of the system. Finally, the process capability (Pc) was defined for the distribution uniformity variable. The results showed statistical superiority for the fertigation process, however, it is noteworthy, that both treatments achieved excellence in their classifications with values above 90% for both CUC and DUC, according to the reference.

Keywords: distribution uniformity, quality control, process capacity.

HAUPENTHAL, S. W.; VILAS BOAS, M. A.; KEPP, N. C.; SIQUEIRA, J. A. C.; TOKURA, L. K.
AVALIAÇÃO DA EFICIÊNCIA DE GOTEJADORES COM UTILIZAÇÃO DE FERTILIZANTE

2 RESUMO

O objetivo do trabalho foi analisar a uniformidade da fertirrigação por gotejamento comparativamente à utilização apenas de água, analisando pelo teste de Tukey a 5% de significância para os coeficientes CUC e DUC, definindo a capacidade do processo a partir do índice de capacidade do processo (Cp). O experimento foi realizado em bancada de testes no Laboratório de Irrigação e Fertirrigação (LIF) da Universidade do Oeste do Paraná, onde no primeiro tratamento, foi utilizada água para o processo de irrigação e no segundo tratamento, foi diluído fertilizante comercial no reservatório para realização da fertirrigação. A estatística experimental constitui uma análise de variância com posterior desdobramento da interação e

teste Tukey a 5% de probabilidade para comparação das médias das uniformidades, vazão e pressão do sistema. Por fim, definiu-se a capacidade do processo (C_p) para a variável de uniformidade de distribuição. Os resultados mostraram superioridade estatística para o processo de fertirrigação, entretanto, salienta-se, que ambos os tratamentos obtiveram excelência em suas classificações, com valores superiores a 90% tanto para o CUC quanto para o CUD, segundo o referencial.

Palavras-chave: uniformidade de distribuição, controle de qualidade, capacidade de processo.

3 INTRODUCTION

The growing need for water resources to serve all sectors, whether urban, industrial or even agricultural, in the irrigation sector, drive research aimed at qualitative and rational reasonable of water (SILVA; TAVARES; SOUZA, 2013).

Meanwhile, the increase in population requires increasing quantities and promotes competition for water between agriculture and other sectors of the economy (ALVES et al., 2015). Thus, farmers are advised to consider more carefully the adoption of strategies to minimize consumption (COSTA; ORTUÑA; CHAVES, 2007).

In addition, the increasing occurrence of drought periods is directly affecting both agricultural production and productivity (PELLING et al., 2004), so the efficient use of water and fertilizers is essential to ensure sustainable food production (WU et al., 2019).

To minimize water consumption and seek better efficiencies, the use of a localized irrigation system is an option, since it is characterized by better distribution uniformity, application efficiency and water productivity in relation to furrow and sprinkler irrigation (DOUH et al., 2013), drip irrigation has the characteristic of applying water close to the soil surface with less intensity, high frequency and closeness to the root zone of the plant, thus keeping the soil of the root zone of the plant near the field capacity (OLIVEIRA et al., 2016).

However, there is a lack of critical analysis in relation to the quality of uniformity within the irrigation system, that for Reis et al. (2006), the evaluation of the performance of an irrigation system is a fundamental step before any irrigation management strategy is implemented. Mantovani and Ramos (1994) affirm that the uniformity of irrigation has the basic objective of improving the productivity and profitability of the property and for Bernardo, Soares and Mantovani (2009), it is of paramount importance to determine the uniformity of water distribution in any method of irrigation.

It is stated that in cases where non-pure water is used, such as fertigation, the dripper system requires monitoring, which can be performed by quality control statistics (HERMES et al., 2013; JUCHEN; SUSZEK; VILAS BOAS, 2013). This methodology checks values outside statistical control, in addition to non-random patterns, such as trends (MONTGOMERY, 2016).

Thus, this work aimed to evaluate the performance of a drip irrigation system installed on a test bench, to diagnose the interference of the application of fertilizers on uniformity. Therefore, the Christiansen uniformity coefficient (CUC) and Distribution uniformity coefficient (DUC) were determined, and the irrigation system classification was verified according to the reference, the interference of the fertilizer use in the uniformity was established from the comparative of averages by the Tukey test at 5% of significance, where the

capability of the process was established through the process capacity index.

4 MATERIAL AND METHODS

The experiment was developed at the Irrigation and Fertigation Laboratory (LIF), in the experimental field of the Agricultural Engineering course at the State University of Western Paraná, Cascavel, PR, at geographic coordinates 24° 54' 0" South and 53° 31' 48" West.

For the experiment, a drip irrigation bench was used 5 meters long and 1.55 m

wide and four pulleys through which the drip tubes passed, totaling 10 meters of lateral line. A 0.5 HP pump was installed, providing a flow rate of 2.07 m³ h⁻¹, at 100 kPa. At the beginning of the first drip side line, a manometer was installed to check the inlet pressure of the irrigation system, while the second manometer was installed at the end of the fourth side line to check the pressure at the end of the system. The platform consists of steel profiles and cables for lifting, allowing the creation of slopes for the lateral line. Figure 1 shows the design of the test bench.

Figure 1. Illustration of the test bench for drip irrigation system.

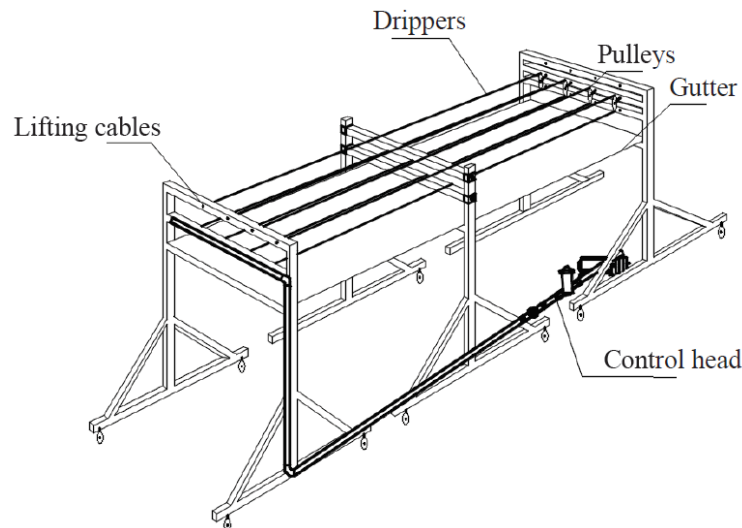

Source: Szekut et al. (2018).

Figure 2 shows the functioning of the system, as it can be observed that the circulation of water (treatment 1) or fertilizer (treatment 2) is cyclical, starting from the water pump (1), passing through the main piping, distributed by the lateral lines of drippers (2), where the flow rate of the drippers selected according to the

methodology was collected, the remainder of the flow of the other drippers flow through the first gutter (3), reaching a second gutter (4), which has an outlet connected to the reservoir (5) that supplies water to the pump, thus, the system has your administered operation.

Figure 2. Operation of the drip irrigation experiment on the bench.

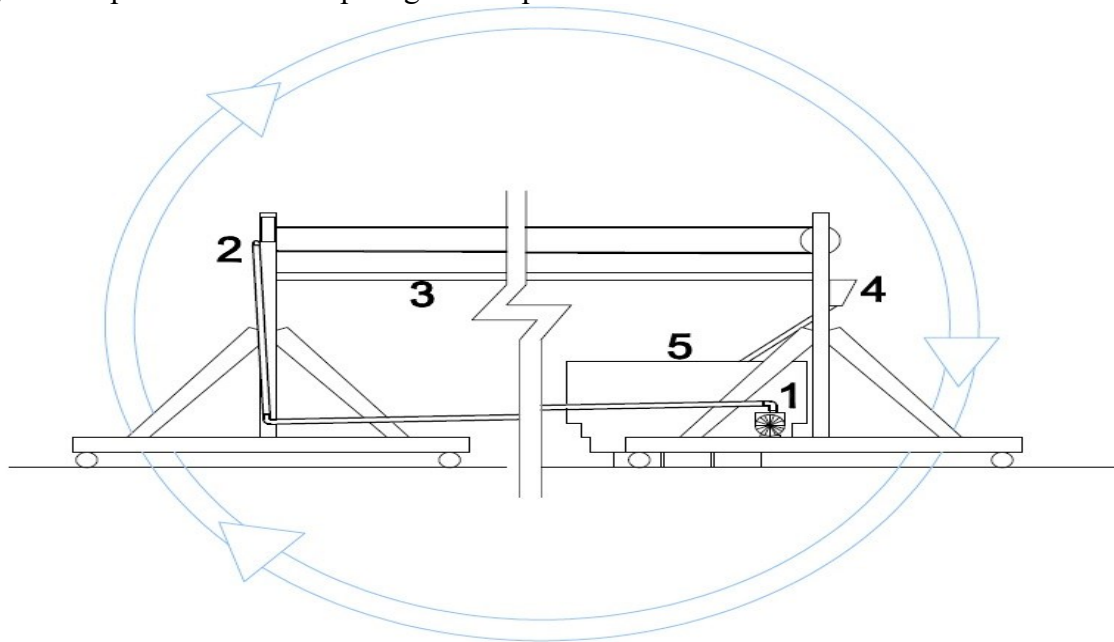

The drip irrigation tube used was the Brasil Drip® brand, Pantanal model, able to be used both for surface and subsurface irrigation, consisting of turbulent flow emitters of the labyrinth type, with insertion of dripper inside the factory tube, with a spacing of 0.20 m between the drippers, with a mechanism against the suction of debris, with variable flow from 1.23 to 2.48 L h⁻¹ and pressure from 39.23 to 147.1 kPa.

A disc filter of 120 mesh from the Irritec® brand, model FLD and two digital pressure gauges from the brand Instrutemp®, model 8215 (100 mwc), were the other equipment of the irrigation system.

The methodology adopted to collect the flow rate of the drip irrigation system was carried out according to Keller and Karmelli (1975), collecting the flow rate of 16 drippers (1st, 1/3rd, 2/3rd and last) for the four lines. There were 25 repetitions per treatment, both for irrigation and for fertigation, this being with the dilution of the Agrodomus® brand fertilizer, hydroponic kit for vegetation in the reservoir with the proper proportionality, totaling 50 repetitions. It is noteworthy that all repetitions were made with the same four drip tubes, initially for water, and later for

fertigation, so as not to cause possible obstruction caused by the fertilizer. Therefore, since it is a closed system, recirculation of water or water plus fertilizer fulfilled the function of simulating a system in the field. Emphasizing that to start the tests, the system was turned on to stabilize the flow and pressure during the test period.

For this research, it was determined 3 minutes of collection, in spite of the methodology and some works presenting 5 minutes of collection, this time was chosen because it does not characterize difference significant of values since the system was stabilized both in pressure of inlet and end of the irrigation system, as in flow of the drippers before of the beginning of the tests, being able to consider that the shorter the collection time without change in the precision of the results, the lesser the expenses with the tests.

To check uniformity, the following treatments were adopted: T1: Irrigation with clean water; T2: Fertigation. In both treatments, the calculation procedures were carried out according to the proposed methodology, also defining the average of the uniformities, the flow rate of the drippers, and the pressure of the system as

well as their respective coefficients of variation.

The response variables of the tests were the drip flow rate ($L h^{-1}$) and the electrical conductivity measured by the TDS & EC Meter (Microohm) in the case of fertigation, and the Tukey average test was performed for uniformity as well as for the pressure and flow rate values in order to determine the superiority or statistical equality of a treatment.

With the data of the water flows of the irrigation system, Christiansen's uniformity coefficients (CUC) proposed by Christiansen (1942), and the distribution uniformity coefficient (DUC) were calculated, from Equations 1 and 2, respectively.

The CUC is one of the most used, as it adopts the absolute mean deviation as a measure of dispersion, as can be seen in Equation 1.

$$CUC = 100 \left\{ 1 - \frac{\sum |x_i - x_{med}|}{n \cdot x_{med}} \right\} \quad (1)$$

Where: CUC: Christiansen's Uniformity Coefficient (%); x_i : Individual values of the volume of water contained in the collectors (mm); x_{med} : General average of the volume of water collected (mm); n : Number of collectors in the test area.

Lopez et al. (1992) argue that it is more coherent to evaluate uniformity according to the areas that receive less water, therefore, it is necessary to use the distribution uniformity coefficient (DUC), determined from Equation 2.

$$DUC = 100 \left(\frac{x_{25}}{x_{med}} \right) \quad (2)$$

Where: DUC: Distribution uniformity coefficient (%); x_{25} : Average of the lowest quartile of water volumes in the collectors (mm); x_{med} : general average of the collected water volume (mm).

For the classification of CUC and DUC, Table 1 was used, according to Keller and Bliesner (2009), in order to identify the classification of the irrigation system.

Table 1. CUC and DUC classification for drip irrigation systems

Classification	CUC (%)	DUC (%)
Excellent	> 90	> 90
Good	90 – 80	90 – 80
Regular	80 – 70	80 – 70
Bad	70 – 60	70 – 60
Unceptable	< 60	< 60

Source: Keller and Bliesner (2009)

Finally, the value of the process capacity index was calculated, since they are used to determine whether a process is capable of meeting a tolerance range. For that, Equation 3 was used.

$$C_p = \frac{UCL - LCL}{6\sigma} \quad (3)$$

Where: UCL: Upper control limit; LCL: Lower control limit; σ : Standard deviation estimator.

According to Montgomery (2009), the process is capable if the specification limits previously established by standards are adequately greater than the control range. Classifying the process capacity considering that, if the C_p value > 1.33, the process is capable or adequate, according to the specifications; if $1 < C_p < 1.33$, the process is acceptable; if $C_p < 1$, the process is incapable or inadequate.

Chen, Huang and Huang (2007), after studying the capacity of the process, defined that this index, can be used not only to monitor the stability of the process, but also to monitor the quality of the same, following specification indexes and evaluating its stability.

Through Minitab (2012), the process capacity (Cp) was calculated using bilateral limits according to the classification of Keller and Bliesner (2009), which classifies uniformity as excellent with values above 90% for CUC and DUC.

5 RESULTS AND DISCUSSION

5.1 Descriptive data statistics

Tables 2 and 3 present the average variation between treatments for the drip irrigation and fertigation, in which Christiansen's uniformity values, distribution uniformity, flow rate and pressure are indicated, together with the values of the variation coefficients of each variable.

Table 2. Average variation between irrigation and fertigation treatments over the uniformity

Analyze	CUC (%)		DUC (%)	
	Mean	CV (%)	Mean	CV (%)
Irrigation	91.90 a	4.21	93.24 b	2.7
Fertigation	92.12 a	2.47	95.37 a	0.66

CUC = Christiansen's uniformity coefficients; DUC = Distribution uniformity coefficient; CV = Coefficient of variation.

The means followed by the same letter in the column do not differ statistically by the Tukey test at the 0.05 probability level.

Table 3. Average variation between irrigation and fertigation treatments over the flow rate and pressure

Analyze	Flow rate (L h ⁻¹)		Pressure (kPa)	
	Mean	CV (%)	Mean	CV (%)
Irrigation	1.58 b	4.03	69.63 b	0.96
Fertigation	1.66 a	3.17	71.03 a	2.75

CV= Coefficient of variation.

The means followed by the same letter in the column do not differ statistically by the Tukey test at the 0.05 probability level.

When analyzing the coefficients between treatments, we can see the statistical similarity between CUC and the superiority of fertigation in the DUC, similarly, the statistical superiority of the DUC occurs for flow rate and pressure, therefore, it can be defined that the increase in pressure values leads to an increase in flow rate values converging to greater uniformity.

Based on the coefficient of variation, it can be said that the data are homogeneous, since their values were less than 10% (MONTGOMERY, 2009). However, the lower variability in the average water flow rate with fertilizer can be explained by the

use of polymers that contain urea particles, also present in the fertilizer used in this experiment, which are soluble in water, that can reduce drag and to lead to lower pressure losses in the tubes (AL-YARRI et al., 2009).

Similar to the results found by Szekut et al. (2018), where in their study of a drip irrigation system using pure water, fertilizers and biofertilizers, they obtained the best quality control conditions for the use of fertigation.

The conductivity analysis for the fertigation system is shown in Table 4, with the average value (Micro ohm) and the coefficient of variation for the 25 repetitions

of the flow of the 16 drippers collected according to the methodology, together with the uniformity coefficients of the

conductivity, seeking to diagnose the efficiency distribution of fertilizer in the drip irrigation system.

Table 4. Average between fertigation conductivity data

Analyze	Mean (Microohm)	CV (%)	CUC (%)	DUC (%)
Conductivity	1423.14	1.01	99.31	99.04

CUC = Christiansen's uniformity coefficients; DUC = Distribution uniformity coefficient; CV = Coefficient of variation.

Considering the uniformity values for the conductivity parameter, where for such variable the fertilizer distribution response over the drip system fits, it is defined that there was a supply considered excellent in terms of classifications. Therefore, the fertilizer application obtained an equal distribution within the system, that is, statistically, the same amount of fertilizer was applied from the first to the last emitter.

5.2 Flow rate dispersion chart for irrigation and fertigation lines

To demonstrate the dispersion of the unitary flows of the 50 drippers in lines 1 and 4, representing the lateral inlet and the final

line of the system, for the irrigation and fertigation treatments, Figure 3 was elaborated. The flow rate of the 50 drippers from both lines was collected for 3 minutes, both for irrigation and for fertigation. Search better visualization of the decrease to the increase in flow in relation to the average a central line was stipulated that refers to the average calculated from the manufacturer in relation to the flow as a function of pressure. The average flow defined by the manufacturer was determined according to the power regression calculated from the data provided in the company catalog, where $\text{Flow} = 0.182 * \text{Pressure}^{0.522}$ with R^2 of 99.3%.

Figure 3. Flow dispersion graph in relation to that stipulated by the manufacturer of lines 1 and 2 in irrigation (a) and lines 1 and 4 in fertigation (b).

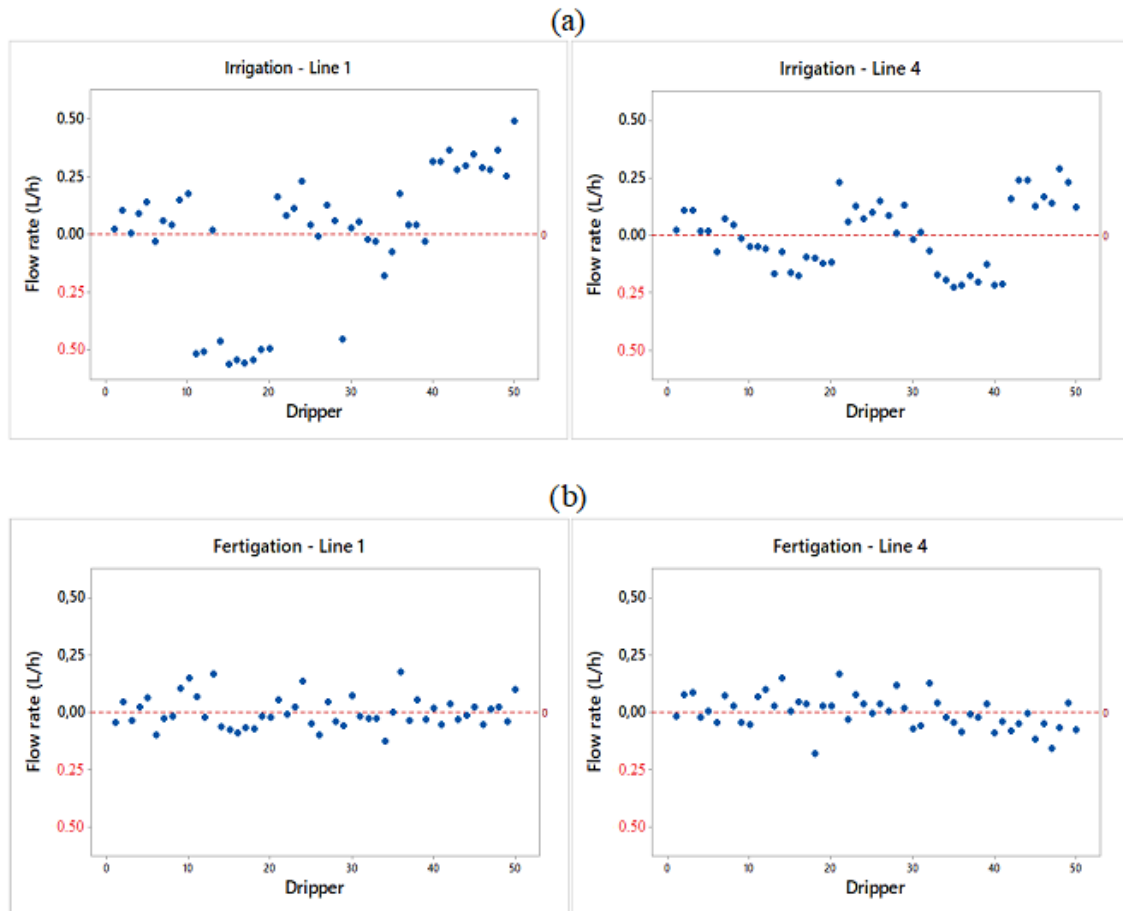

Analyzing the irrigation treatment first, it can be observed that 10 drippers out of a total of 50 in line 1 have a deficit of 0.5 $L h^{-1}$ in relation to the average, that is, these drippers have presented an average decrease of more than 30% in its flow rates, in line 4, 11 drippers showed a decrease of approximately 15%. With the average value of the standard deviation of 0.29 and 0.15 for lines 1 and 4, respectively, of the irrigation treatment, we can say that there is a high dispersion of values in relation to the average.

Regarding fertigation, there is an approximation of the flow values in relation to the stipulated average, with sporadic points around 0.25 $L h^{-1}$, both for increasing and the reduction of the flow rate, thus concluding regularity when using fertilizer

in the process irrigation, since the standard deviation was 0.07 for both lines.

When analyzing both treatments together, it was verified that for the 100 drippers in lines 1 and 4, 70% had flow rates lower than that stipulated by the manufacturer, characterizing a decrease in the applied water depths values, however it is emphasized that within the dimensioning of the water application the total irrigation required passes through the correction of the application efficiency, so as it was found an average uniformity of 93%, the supplementation of adjoining calculations will supply the lowest flow rate presented by 70% of drippers.

According to Bernardo (1995), the greater the uniformity of application, the greater the efficiency of the system with less water waste and, consequently, the greater

the productivity of the crop. Uniformity that is characterized in the dispersion graphs regarding the flow rate of the fertigation system, in which the proximity of the points in the central line defines the low standard deviation and, therefore, greater uniformity in the flow rate of the drippers (Figure 3b).

5.3 Process capacity index

Table 5 presents the calculated values of the process capacity index (Pc), seeking a more reliable analysis of the results of distribution uniformity. Therefore, the DUC variable was used to diagnose the capacity of the process to irrigate and fertigation. Presenting the capacity indices for the uniformity coefficient, using 100% to 90% and 90% to 80% limits.

Table 5. Process capacity index (Pc) for the Distribution uniformity coefficient (DUC).

	DUC (%)	Pc
Irrigation	90 - 100	0,55
	80 - 90	2,25
Fertigation	90 - 100	2,88
	80 - 90	8,23

As for irrigation, the process only proved capable for a classification of good irrigation uniformity (BERNARDO; SOARES; MANTOVANI, 2009), where only for this classification exceeded the limit of 1.33 (MONTGOMERY, 2009). In the case of fertigation, the process was capable of being classified as excellent (BERNARDO; SOARES; MANTOVANI,

2009), as it surpassed the requirement of Montgomery (2009).

Studies with drip irrigation (HERMES et al., 2015; KLEIN et al., 2015) showed similarity to the values found in this study, where the irrigation system was capable according to the classification.

6 CONCLUSIONS

The highest values of uniformity were defined for fertigation, reaching the level of excellence according to the classification, as well as the lowest values of coefficient of variation. However, pure water also presented excellent uniformity. The conductivity, which is the response parameter of the fertilizer distribution, reached uniformity greater than 99%.

Therefore, from the results obtained in the drip irrigation bench tests, we can conclude that improvements in uniformity

occurred when using fertigation, presenting a process capacity for distribution uniformity greater than 90%, thus, it is pointed out the efficiency of the system to perform fertigation without interfering with the uniformity pattern.

7 ACKNOWLEDGMENTS

This work was carried out with the support of the Coordination for the Improvement of Higher Education Personnel - Brazil (CAPES) - Financing Code 001.

8 REFERENCES

- ALVES, E. S.; ARAUJO, L. M.; ALVES, J. S. D.; SANTOS J. E. O; ZIMBACK C. R. L. Geoestatística aplicada a uniformidade de aplicação de água em sistemas de irrigação por gotejamento usado e novo. **Revista Brasileira de Agricultura Irrigada**, Fortaleza, v. 9, n. 3, p. 127-135, 2015.
- AL-YARRI, M.; SOLEMANI, A.; ABU-SHARKH, B.; AL-MUBAIYEDH, U.; ALSARKHI, A. Effect of drag reducing polymers on oil-water flow in a horizontal pipe. **International Journal of Multiphase Flow**, Elmsford, v. 35, n. 6, p. 516-524, 2009.
- BERNARDO, S. **Manual de irrigação**. 6. ed. rev. e ampl. Viçosa: UFV, 1995.
- BERNARDO, S.; SOARES, A. A.; MONTOVANI, E. C. **Manual de irrigação**. 8. ed. Viçosa: UFV, 2009.
- CHEN, K. S.; HUANG, H. L.; HUANG, C. T. Control charts for one-sided capability indices. **Quality & Quantity**, Dordrecht, v. 41, n. 3, p. 413-427, 2007.
- CHRISTIANSEN, J. E. **Irrigation by sprinkling**. Berkeley: University of California, 1942. (Bulletin, 670)
- COSTA, J. M.; ORTUNÃ, M. F.; CHAVES, M. M. Deficit irrigation as a strategy to save water: physiology and potential application to horticulture. **Journal of Integrative Plant Biology**, Lisboa, v. 49, n. 10, p. 1421-1434, 2007.
- DOUH, B.; BOUJELBEN, A.; KHILA, S.; BEL HAHMGUIDICHE, A. Effect of subsurface drip irrigation system depth on soil water content distribution at different depths and different times after irrigation. **Larhyss Journal**, Biskra, v. 13, n. 13, p. 7-16, 2013.
- HERMES, E.; VILAS BOAS, M. A.; GOMES, S. D.; GOMES, B. M.; REIS, C. F. Quality control in irrigation and fertigation with cassava processing wastewater into drip system. **Journal of Food, Agriculture & Environment**, Helsinki, v. 11, n. 2, p. 1427-1433, 2013.
- HERMES, E.; VILAS BOAS, M. A.; RODRIGUES, L. N.; MELLO, E. L.; GONCALVES, M. P.; LINS, M. A.; BERGER, J. S. Process capacity index in drip irrigation with cassava wastewater processing. **African Journal of Agricultural and Resource Economics**, Nairóbi v. 10, n. 12, p. 1427-1433, 2015.
- JUCHEN, C. R.; SUSZEK, F. L.; VILAS BOAS, M. A. Irrigação por gotejamento para produção de alface fertirrigada com águas residuárias agroindustriais. **Irriga**, Botucatu, v. 18, n. 1, p. 243-256, 2013.
- KELLER, J.; KARMELI, D. **Trickle irrigation design**. Glendora: Rain bird Sprinkler Manufacturing Corporation, 1975.
- KELLER, J.; BLIESNER, R. D. **Sprinkle and Trickle Irrigation**. New York: Chapman-Hall Publishers, 2009.

- KLEIN, M. R.; VILAS BOAS, M. A.; SUSZEK, F. L.; SZEKUT, F. D.; MELLO, E. L.; GOMES, B. M.; SILVA, B. B.; ZUCULOTTO, T. Fertigation quality with drip irrigation system in grape orchard by using the process capability index. **Journal of Food, Agriculture & Environment**, Helsinki, v. 13, n. 22, p. 179-183, 2015.
- LOPEZ, J. R.; ABREU, J. M. H.; REGALADO, A. P.; HERNADEZ, J. F. G. **Riego localizado**. 2. ed. Madrid: Centro Nacional de Tecnologia de Regadíos, 1992.
- MANTOVANI, E. C.; RAMOS, M. M. Manejo da irrigação. *In*: COSTA, E. F.; VIEIRA, R. F.; VIANA, P. A. **Quimigação**: aplicação de produtos químicos e biológicos via irrigação. Brasília, DF: Embrapa: SPI, 1994.
- MINITAB. **User'Guide Release 16 for Windows**. Pennsylvania: Minitab, 2012.
- MONTGOMERY, D. C. **Introdução ao controle estatístico da qualidade**. 4. ed. Rio de Janeiro: LTC, 2009.
- MONTGOMERY, C. D. **Introdução ao controle estatístico de qualidade**. 7. ed. Rio de Janeiro: LTC, 2016.
- OLIVEIRA, E. V.; ARRAES, F. D. D.; TORRES, W. L. V.; SOUZA, S. A.; VIEIRA, W. L. Desempenho de um sistema de irrigação por microaspersão e estimativa da demanda hídrica para diferentes fruteiras no município de Iguatu – CE. **Revista Conexoes: Ciências e Tecnologia**, Fortaleza, v. 10, n. 2, p. 40-46, 2016.
- PELLING, M.; MASKREY, A.; RUIZ, P.; HALL, L.; PEDUZZI, P.; DAO, Q. H.; MOUTON, F.; HEROLD, C.; KLUSER, S. **Reducing Disaster Risk: A Challenge for Development**. 1. ed. New York: United Nations Development Programme, 2004.
- REIS, M. M.; PALADINI, E. P.; KHATOR, S.; SOMMER, W. A. Artificial intelligence approach to support statistical quality control teaching. **Computers & Education**, New York, v. 47, n. 4, p. 448-464, 2006.
- SILVA, V. P. R.; TAVARES A. L.; SOUSA I. F. Evapotranspiração e coeficientes de cultivo simples e dual do coentro. **Revista Horticultura Brasileira**, Brasília, DF, v. 31, n. 2, p. 255-259, 2013.
- SZEKUT, F. D.; AZEVEDO, C. A. V.; VILAS BOAS M. A.; ZUCULOTTO T. Hydraulic performance of drippers with different waters and lateral line slopes. **Revista Brasileira de Engenharia Agrícola e Ambiental**, Campina Grande, v. 22, n. 12, p. 813-818, 2018.
- WU, D.; XU, X.; CHEN, Y.; SHAO, H.; SOKOLOWSK, E.; MI, G. Effect of different drip fertigation methods on maize yield, nutrient and water productivity in two-soils in Northeast China. **Agricultural Water Management**, Amsterdam, v. 213, n. 1, p. 200-211, 2019.